

标记	处数	更改内容	版本	签名	时间

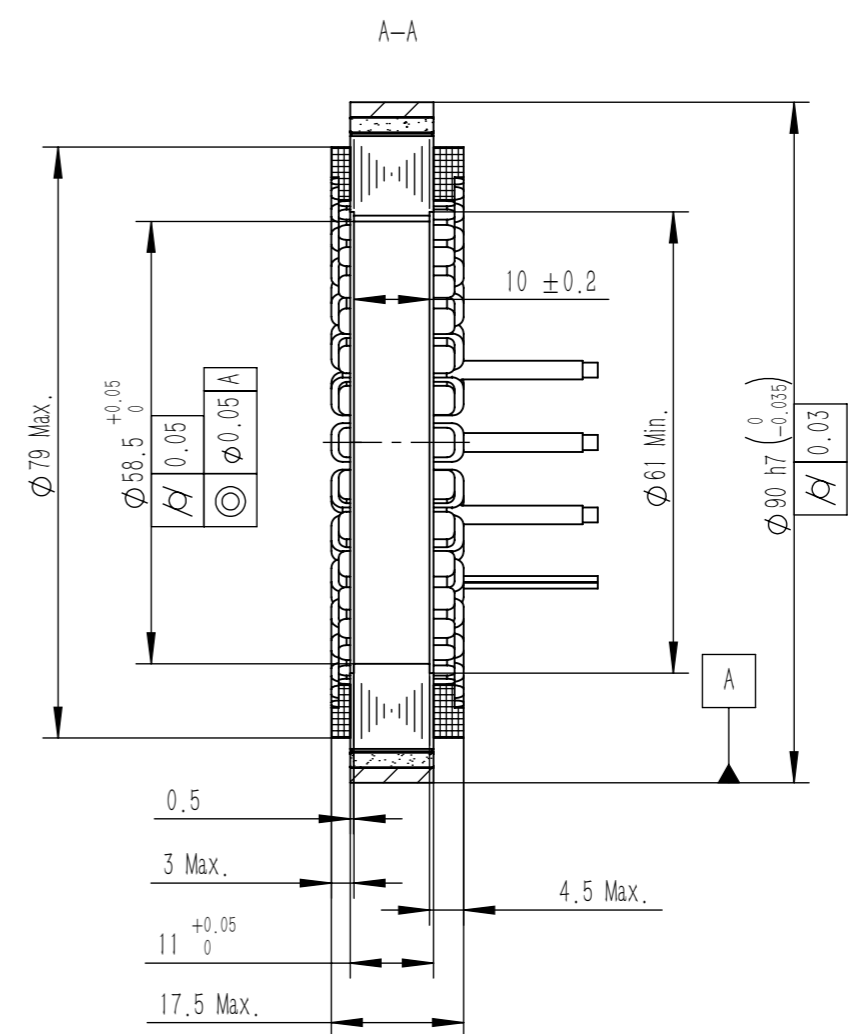

Wire: #14AWG black, white, red, corresponding to V, W, W  
 Wire length 250mm  
 Temperature control wire: #26AWG, yellow and green wires, length: 250mm  
 Temperature Coefficient Thermistor: CA-NTC24C018

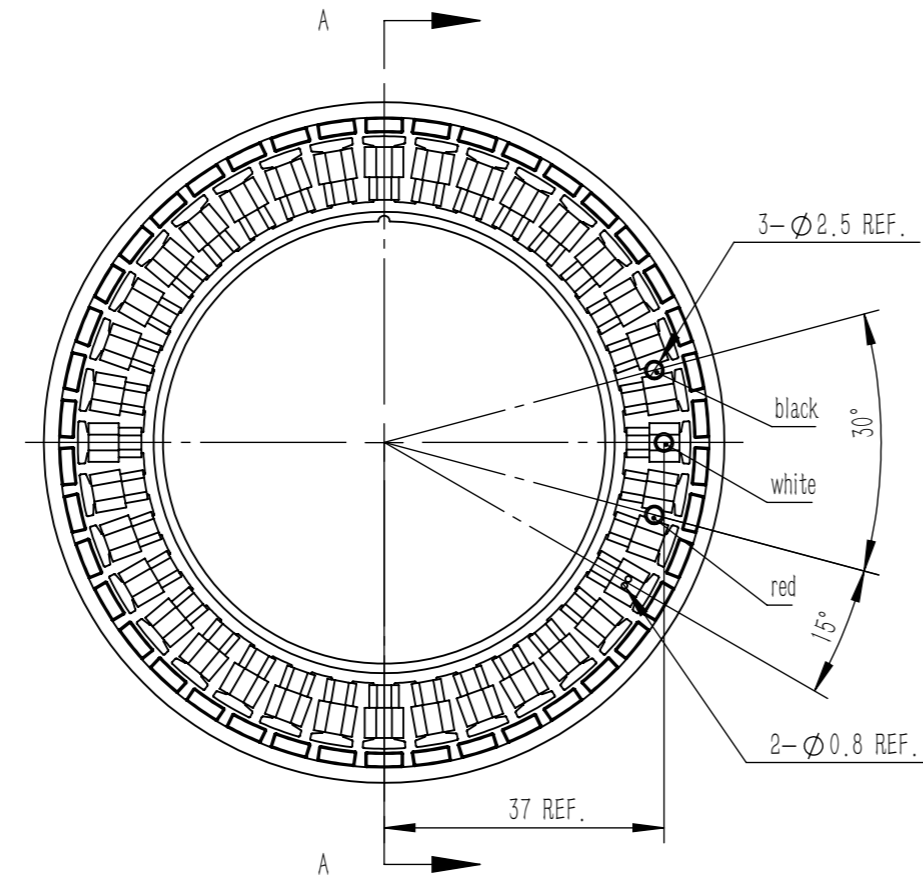
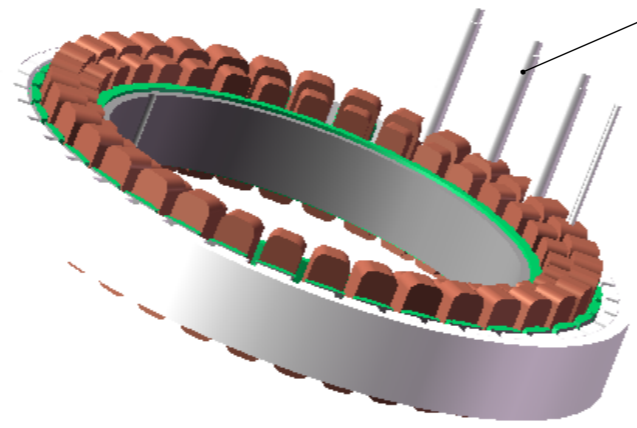

零件代号

Motor Parameter

Model	UE9017
描图	Voltage (V) 48V DC
	Rated output (W) 524.00
描校	Rated torque (Nm) 2
	Instant max torque (Nm) 5.5
旧底图总号	Rated current (Arms) 12
	Instant max current (Arms) 36
底图总号	Rated speed (Rpm) 2500
	Max speed (Rpm) 3020
	Torque constant (Nm/Arms) 0.17
签字	Rotor inertia (kg.cm <sup>2</sup> ) 1.02
	Back EMF coefficient (V/Krpm) 15.8
日期	Resistance (Ω) 0.37
	Inductance (mH) 0.15
	Number of pole-pairs (P) 21

Unmarked Linear Size Tolerance & Angle Reference Table					
Basic Size	Selection Level				Angle
	A	B	C	D	
≤5	±0.02	±0.03	±0.05		0°~30° ±0.1°
>5~20	±0.03	±0.05	±0.1		31°~60° ±0.3°
>20~50	±0.05	±0.1	±0.15		61°~90° ±0.5°
>50~100	±0.1	±0.15	±0.2		
>100	±0.1%	±0.15%	±0.2%		

No.	WI-UE9017DJA01	Describe	UE9017 Frameless Torque Motor		
Materials		Sheet	A3	Number	1
Date	2026/4/3	Versions			A
Design	Fenghua Wang	Page- / Pages-			
Check		MOSRAC			
Approve					