

标记	处数	更改内容	版本	签名	时间

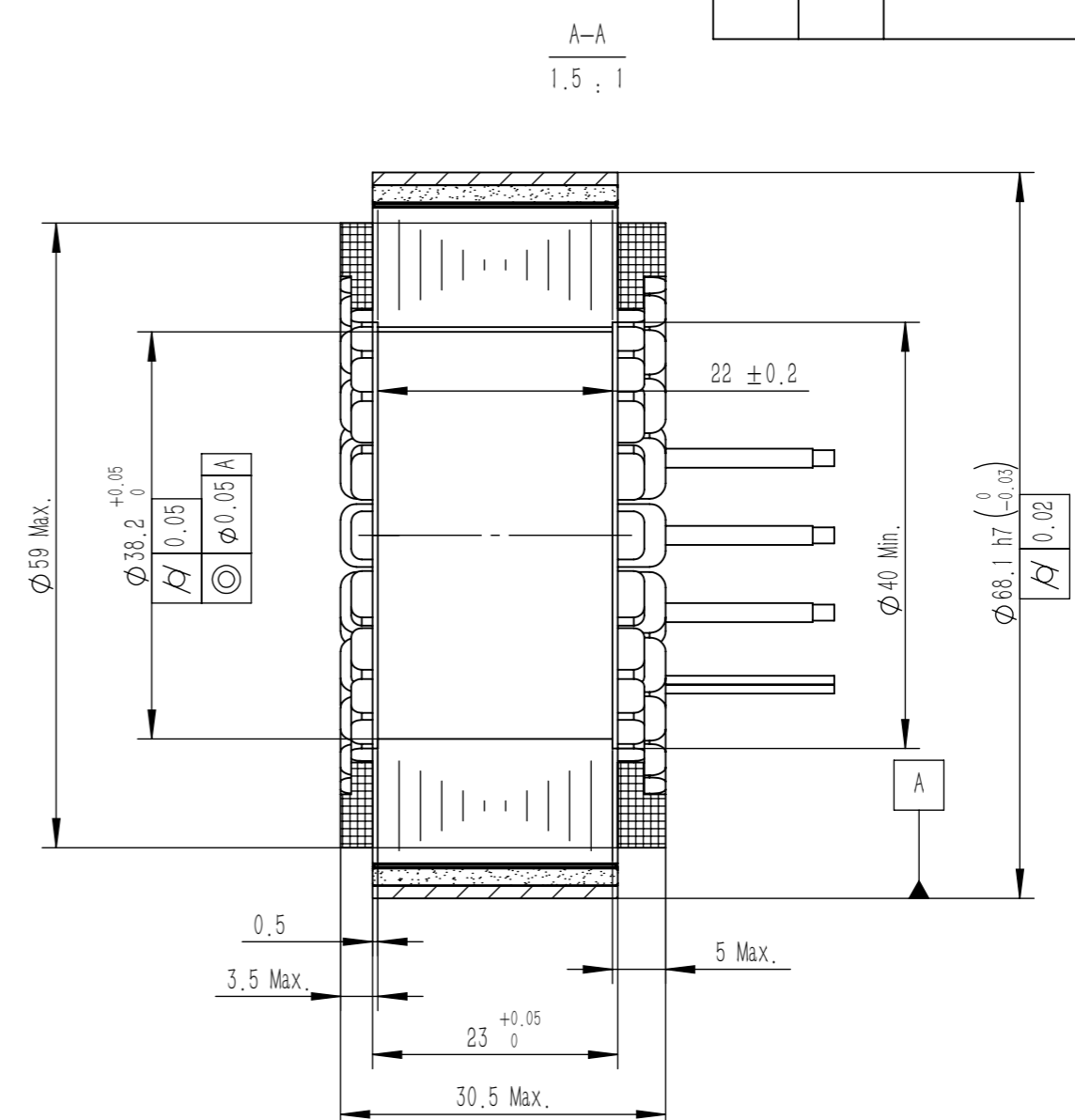
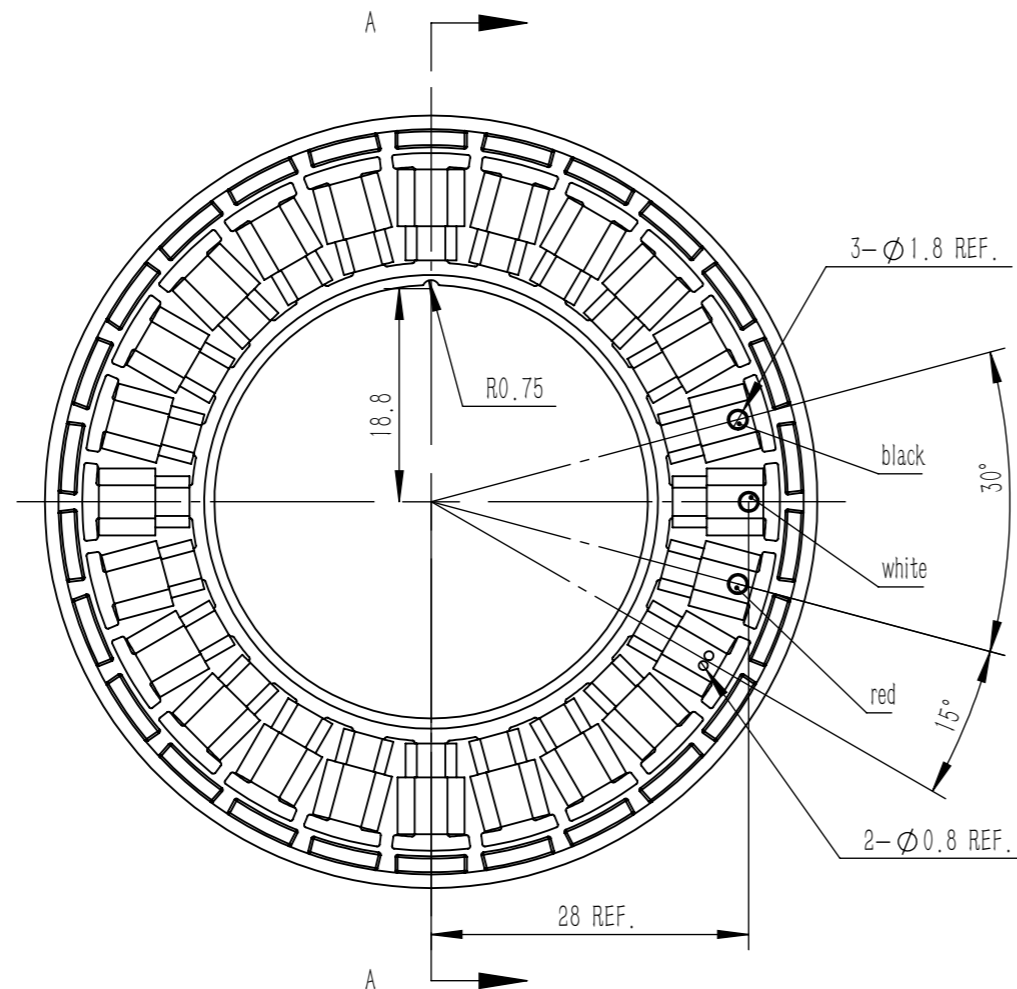

零件代号

借(通)用件登记

描图

描校

旧底图总号

底图总号

签字

日期

Motor Parameter

Model	UE6830
Voltage (V)	48V DC
Rated output (W)	471.60
Rated torque (Nm)	1.8
Instant max torque (Nm)	5.1
Rated current (Arms)	10
Instant max current (Arms)	38
Rated speed (Rpm)	2500
Max speed (Rpm)	2874
Torque constant (Nm/Arms)	0.18
Rotor inertia (kg.cm <sup>2</sup> )	0.8
Back EMF coefficient (V/Krpm)	16.7
Resistance (Ω)	0.4
Inductance (mH)	0.27
Number of pole-pairs (P)	13

Wire: #17AWG black,white,red,corresponding to V, W, W  
 Wire length 250mm  
 Temperature control wire: #26AWG, yellow and green wires, length: 250mm  
 Temperature Coefficient Thermistor: CA-NTC24C018

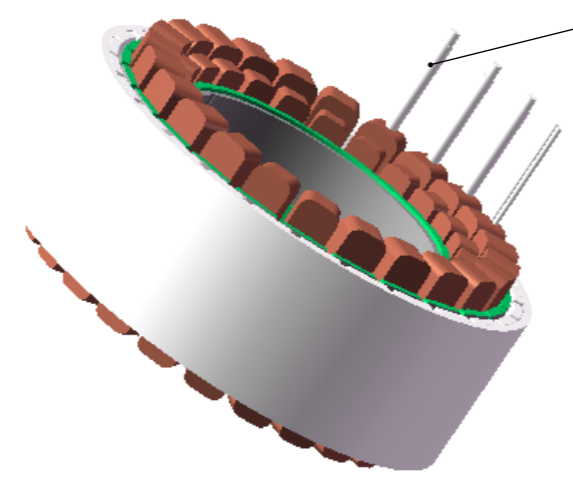

Basic Size	Selection Level				Angle
	A	B	C	D	
≤5	±0.02	±0.03	±0.05		0°~30° ±0.1°
>5~20	±0.03	±0.05	±0.1		31°~60°
>20~50	±0.05	±0.1	±0.15		±0.3°
>50~100	±0.1	±0.15	±0.2		61°~90°
>100	±0.1%	±0.15%	±0.2%		±0.5°

No.	WI-UE6830DJA01	Describe	UE6830 Frameless Torque Motor	
Materials		Sheet	Number	Versions
Date	2026/4/3	A3	1	A
Design	Fenghua Wang	Page- / Pages-		
Check		MOSRAC		
Approve				

