

保密

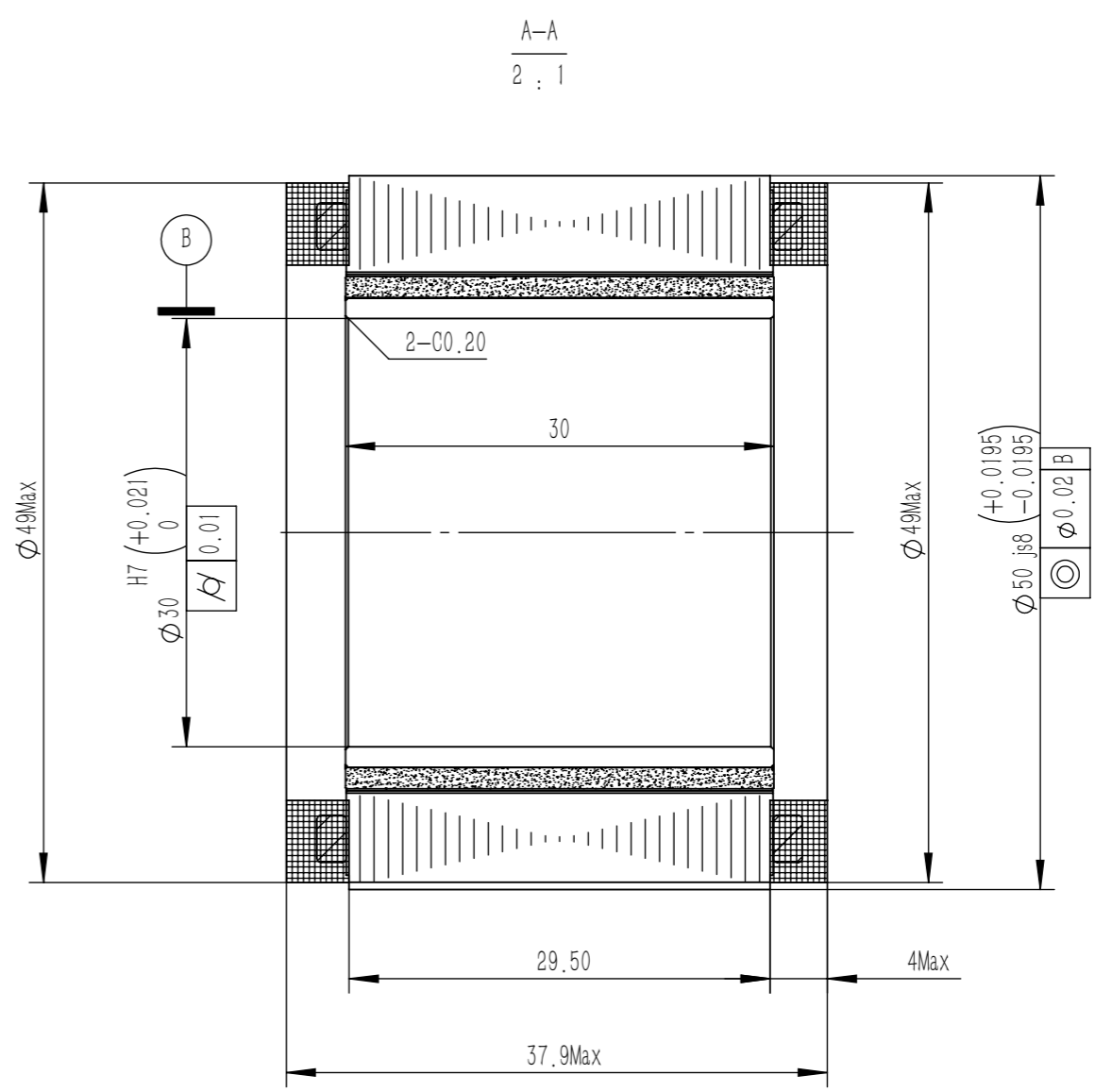

Model	U5037
DC voltage (VDC)	48
Rated output (W)	220
Rated torque (N.m)	0.7
Rated current(A)	5.8
Rated speed (rpm)	3000
Maximum speed (rpm)	4500
Instant max torque (N.m)	2.1
Instant max current (A)	17.5
Coil resistance (ohms@20°C)	0.45
Coil inductance (mH)	0.35
Torque parameters (Nm/A)	0.120
Back EMF coefficient (Vrms/KRPM)	7.5
Number of pole-pairs (2P)	10
Rotor inertia (Kg.cm2)	0.163
Winding connection way	Y

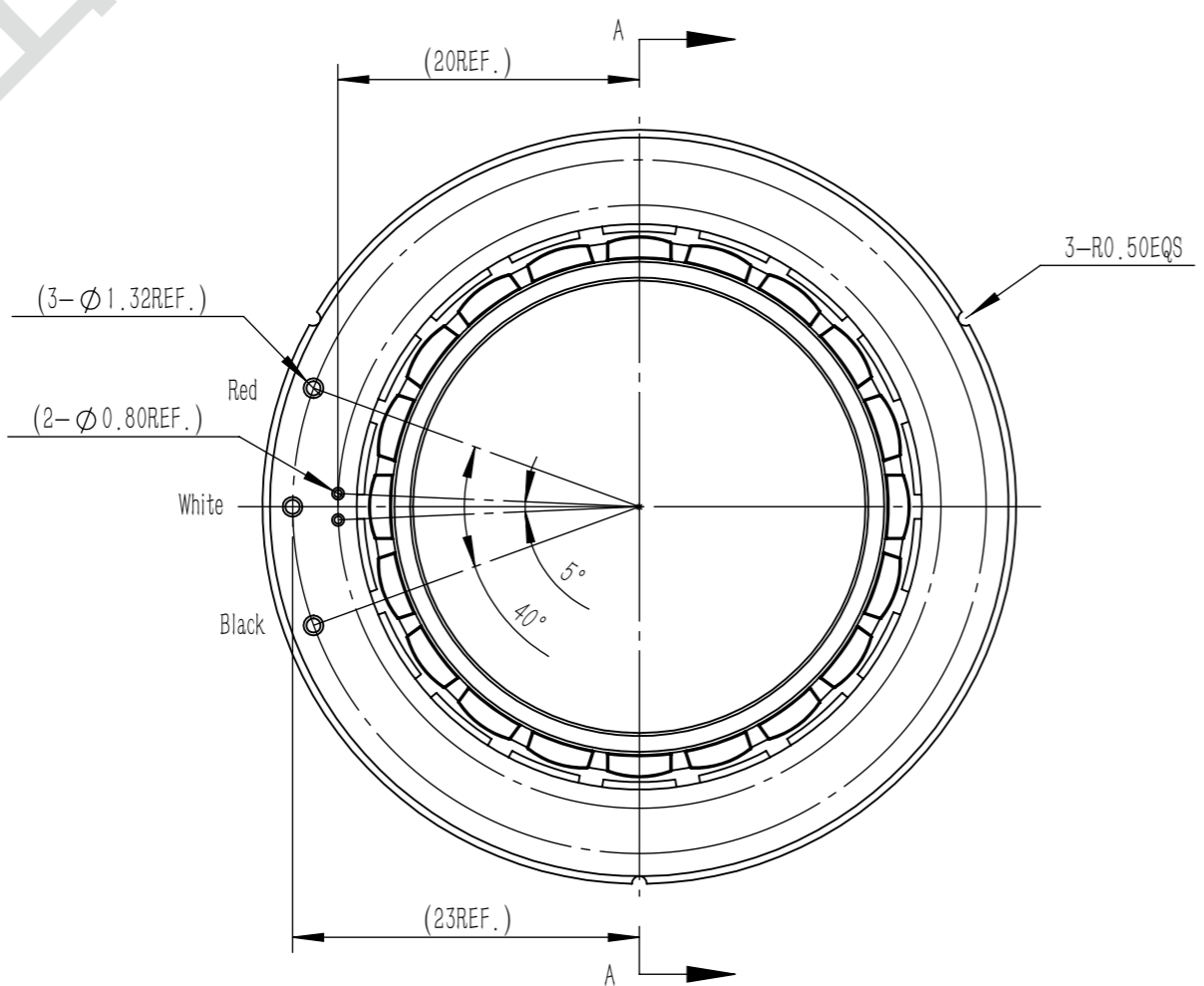
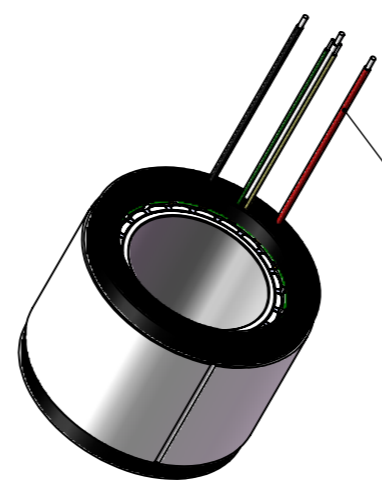

Cable: #20AWG red,black,white,corresponding to U, V, W
 Wire length 250mm
 Temperature control wire: #26AWG, yellow and green wires, length: 250mm
 Temperature Coefficient Thermistor: CA-NTC24C018

								MOSRAC 强和电机			
								Drawing Sign	Version	V1.0	U5037 Frameless Torque Motor
Marker	Place number	Drawing Zone	Rev. No.	Signature	Month-Day-Year			Weight	WI-YF-U5037DJA01		
Designer	ZZY	2025/11/25	Unification					Scale	MOSRAC Motor R&D Department		
Checker			Process Engineer								
Technical	CMH	2025/11/25	Approval						Perspective		
								Sheet 1 of 1			