

Collaborative Robots | AGVs | Industrial | Robotic Joints

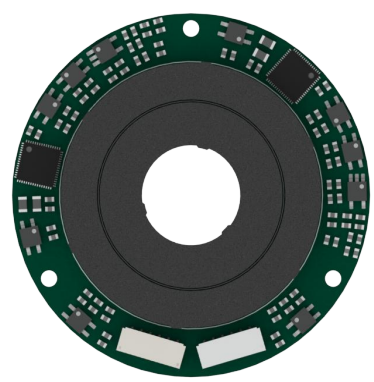

DP1038 PRODUCT GUIDE

High Accuracy | Hollow Shaft | Low Profile | Non-contact

1、 Introduction

DP1038 adopts an inductance technique to measure precise angle. The output signal shows the true absolute angular position of the rotor relative to the stator without the need of any motion at power up. Non-contact makes it easy to achieve high precision, high reliability angle measurement in harsh environments. The hollow shaft and low profile allow easy integration with through-shafts, slip-rings, direct drive motors, optical-fibers, pipes or cables. Installation does not require precisely machined mounting components or couplings.

The encoders are equipped with BiSS-C, Asynchronous serial (UART), SSI communication interfaces and offer a high resolutions per revolution. Providing customized extension options when there are more special requirements to meet.

The DP Thin-Type Inductive Dual-Output Encoder can simultaneously output two position signals. This encoder features two independent position detection and signal output mechanisms, enabling redundant applications and significantly enhancing product reliability. It is suitable for critical applications such as medical, defense, aerospace, industrial automation, and robotics.

- ✓ **Non-contact**
- ✓ **Hollow shaft**
- ✓ **Low profile**
- ✓ **High precision**
- ✓ **True absolute system**
- ✓ **Low power consumption**
- ✓ **No maintenance**
- ✓ **No bearings**
- ✓ **Easy to install**
- ✓ **Tolerance to EMI / RFI**
- ✓ **Shock and Vibration Tolerance**
- ✓ **customized extension options**



2、 Technical Specifications

General

Resolution	17-19bit
Maximum static error	$\pm 0.015^\circ$
Repetitive error	± 2 LSB
Maximum operational speed	6000 rpm
Measurement range	Single turn
Rotation direction	Adjustable CW/CCW

Mechanical

Outer\Inner\Height	38\10\3.8mm
Allowable mounting eccentricity	± 0.1 mm
Allowable axial mounting tolerance	0.6 ± 0.2 mm
Rotor inertia	0.05/0.16kg·mm ²
Weight (stator / rotor)	10 g
Material (stator / rotor)	FR-4

Electrical

Supply voltage	5 V
Current consumption	< 80 mA
Communication	SSi、BiSS-C、UART

Environmental

EMC	IEC 61000-6-2、IEC 61000-6-4
Operating temperature	-40°C ~ +125°C
Storage temperature	-50°C ~ +100°C
Relative humidity	0 - 99%
Shock endurance / functional	100 g / 11 ms
Vibration functional	20 g (10 - 2000 Hz)
Protection	IP 40

3、Electrical Connection

3.1 Hardware Interface

DP1038 encoder consists of a stator and two rotors, the stator integrates an angle calculation circuit and an encoding output circuit. The encoder uses a multi-core connector for output (connector interface as shown in the figure below), with the output connector located on the outer edge of the stator. The angle output uses two connectors, and can choose to output interface protocols such as SSI、BiSS-C、RS-422、RS-485.

Interface definition

No.	SSI	RS-422	BiSS-C	RS-485
1	VCC			
2	GND			
3	CLK+	RX+	MA+	/
4	CLK-	RX-	MA-	/
5	DADT-	TX-	SLO-	B-
6	DADT+	TX+	SLO+	A+

SSi/BiSS output signal parameters

Signal delay	< 50 us
Output code	Binary
Maximum data request rate	25 kHz
Clock/ Serial output	Differential RS-422

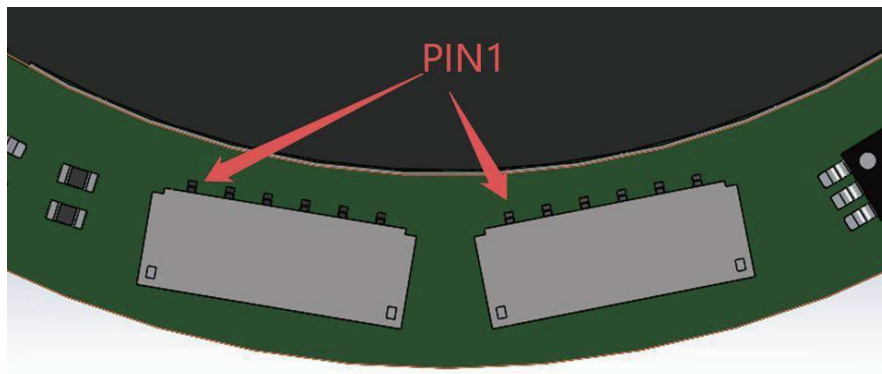

Connector and pin1 position

6-pin Connector: M0611RS-06-GB X0600HI-06G-LPHF (Standard)

3.2 SSi Interface

SSi (Synchronous Serial Interface) is based on the RS-422 hardware standard and is a commonly used interface for angle encoders. The master sends clock and angle encoder synchronized output data. The default clock is high level. The first low level starts data transmission, and the angle encoder transmits the angle data to the master in sequence according to the clock. The timing diagram is as follows:

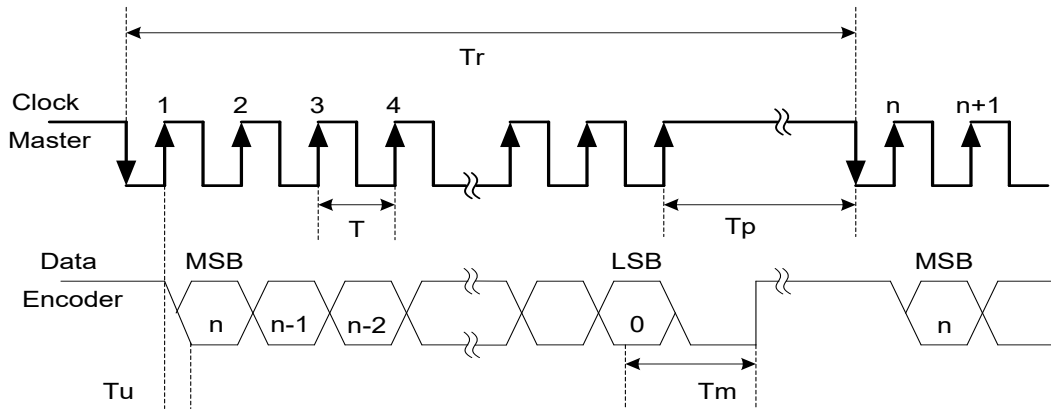

n	Position resolution	12 - 21
$f (T)$	Clock frequency (Clock period)	0.5 - 5.0 MHz
T_u	Bit update time	50 ns
T_p	Pause time	$> 25 \mu s$
T_m	Monoflop time	$> 3 \mu s$
T_r	Time between 2 adjacent requests	$T_r > n * T + 25 \mu s$
$f_r = 1/T_r$	Data request frequency	

3.3 BiSS-C Interface

The BiSS-C communication protocol is a full duplex, bidirectional, high-speed, synchronous serial communication protocol. This interface is also based on the RS-422 hardware standard and is compatible with the SSi interface. It is widely used in high-precision position control absolute encoders. The product uses BiSS-C as a point-to-point configured unidirectional interface, which can serve as one or more slaves connecting to the master, meeting the requirements of BiSS-C unidirectional interface. The timing diagram is as follows:

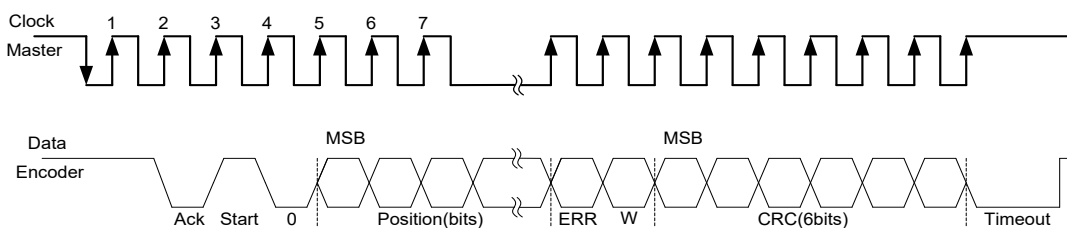

Bit/n		Description	Default Length	Default Length
28	Ack	Period during which the encoder calculates the absolute position, one clock cycle	0	1 bit
27	Start	Encoder signal for "start" data transmit	1	1 bit
26	"0"	"Start" bit follower	0	1 bit
8-25	Position	Absolute Position encoder data		Per resolution
7	Error	BIT (Built In Test option)	1	1 bit
6	Warn	Warning (non active)	1	1 bit
0-5	CRC	*The CRC polynomial		6 bit
--	Timeout	Elapse between the sequential "start" request cycle's		> 30 us

*The CRC polynomial for position, error and warning data is: $x^6 + x^1 + x^0$. It is transmitted MSB first and inverted. The start bit and "0" bit are omitted from the CRC calculation.

3.4 RS-422 UART Interface

Asynchronous serial communication interface over RS422 (UART), by default, the master does not need to send requests, and the encoder automatically outputs data to the master. The update rate of the encoder data is 2000Hz, the baud rate is 460800bps, and the data format is 1 start bit, 8 data bits, 1 even check bit, and 1 stop bit. Each frame of data contains 10 bytes, and the format is shown in the table below.

	BIT	Description	Note
Header	1	5E	Defined Header
	2	AD	
Protocol Flag Bit	3	01	Single byte
Position	4	Most Significant 8 Bits	LSB effective, MSB padding 0
	5	Middle Significant 8 Bits	
	6	Least Significant 8 Bits	
Frame Count	7	Most Significant 8 Bits	0-65535 Accumulate
	8	Least Significant 8 Bits	
Check	9	Most Significant 8 Bits	Accumulate the 3th4th, 5th6th, and 7th8th bytes, taking the lower 16 bits
	10	Least Significant 8 Bits	

3.5 RS-485 UART Interface

RS-485 serial interface, half duplex communication protocol, requires the master to send commands to get the angle position. The data update rate is related to the master request rate. The baud rate is 2.5Mbps, and the data format is 1 start bit, 8 data bits, 0 even check bits, and 1 stop bit. Frame format for reading-out data is as follows:

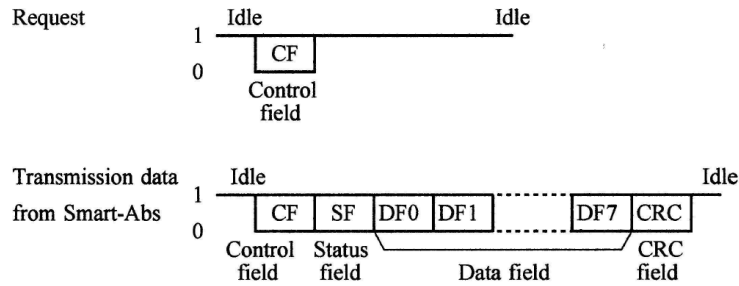

3.5.1 Single turn position request command:

1.Master send command

Sent data (HEX): 0x02

2. The master receives data frames from the encoder

Received data (HEX): 0x02 0x20 0x03 0x02 0x01 0x16

0x02: CF return the same command

0x20: SF defined as follows (LSB first)

Bit0	Bit1	Bit2	Bit3	Bit4	Bit5	Bit6	Bit7
0	0	0	0	EA0	EA1	CA0	CA1

EA0=1 Single turn counting error

EA1=1 Overtemperature, multiturn counting error, battery alarm, or battery error

CA0=1 Communication parity error

CA1=1 Communication stop bit error

0x03 0x02 0x01: DF single turn position (LSB first)

0x16: CRC $G(X) = X^8 + 1$, The code is calculated from all bits

3.5.2 Encoder ID data request command

1. Master send command Sent data (HEX) : 0x92

2. The master receives data frames from the encoder:

Received data (HEX): 0x92 0x20 0x11 0xA3

0x92: CF return the same command

0x20: SF

0x11: Encoder ID, fixed 0x11

0xA3: CRC $G(X) = X^8 + 1$, The code is calculated from all bits

3.5.3 Encoder all data request command

1. Master send command Sent data (HEX) : 0x1A
2. The master receives data frames from the encoder:
 Received data (HEX): 0x1A 0x20 0x03 0x02 0x01 0x11 0x05 0x04 0x00 0x22 0x08
 0x1A: CF return the same command
 0x20: SF
 0x03 0x02 0x01: DF single turn position (LSB first)
 0x11: Encoder ID, fixed 0x11
 0x05 0x04 0x00: DF multiturn position (LSB first) (0x0405 = 1029, Max.65535)
 0x22: Encoder error, defined as follows (LSB first)

Bit0	Bit1	Bit2	Bit3	Bit4	Bit5	Bit6	Bit7
Overspeed	Full absolute status	Counting error	Counter overflow	"0"	Multiturn error	Battery error	Battery alarm

0x08: CRC $G(X) = X^8 + 1$, The code is calculated from all bits

3.5.4 Single turn position reset request command:

1. Master send command Sent data (HEX) : 0xC2
 The reset command should be repeated at least 10 times with a 40us interval to reset the single turn position.
2. The master receives data frames from the encoder:
 Received data (HEX): 0xC2 0x20 0x00 0x00 0x00 0xE2
 0xC2: CF return the same command
 0x20: SF
 0x00 0x00 0x00: DF single turn position (LSB first)
 0xE2: CRC $G(X) = X^8 + 1$, The code is calculated from all bits

4、 Mechanical Mounting

4.1 Dimensions

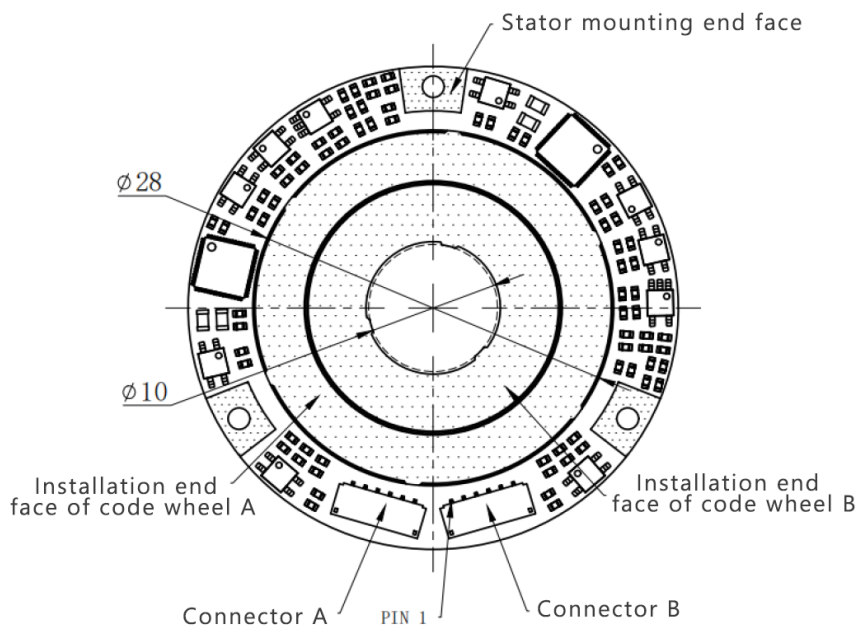
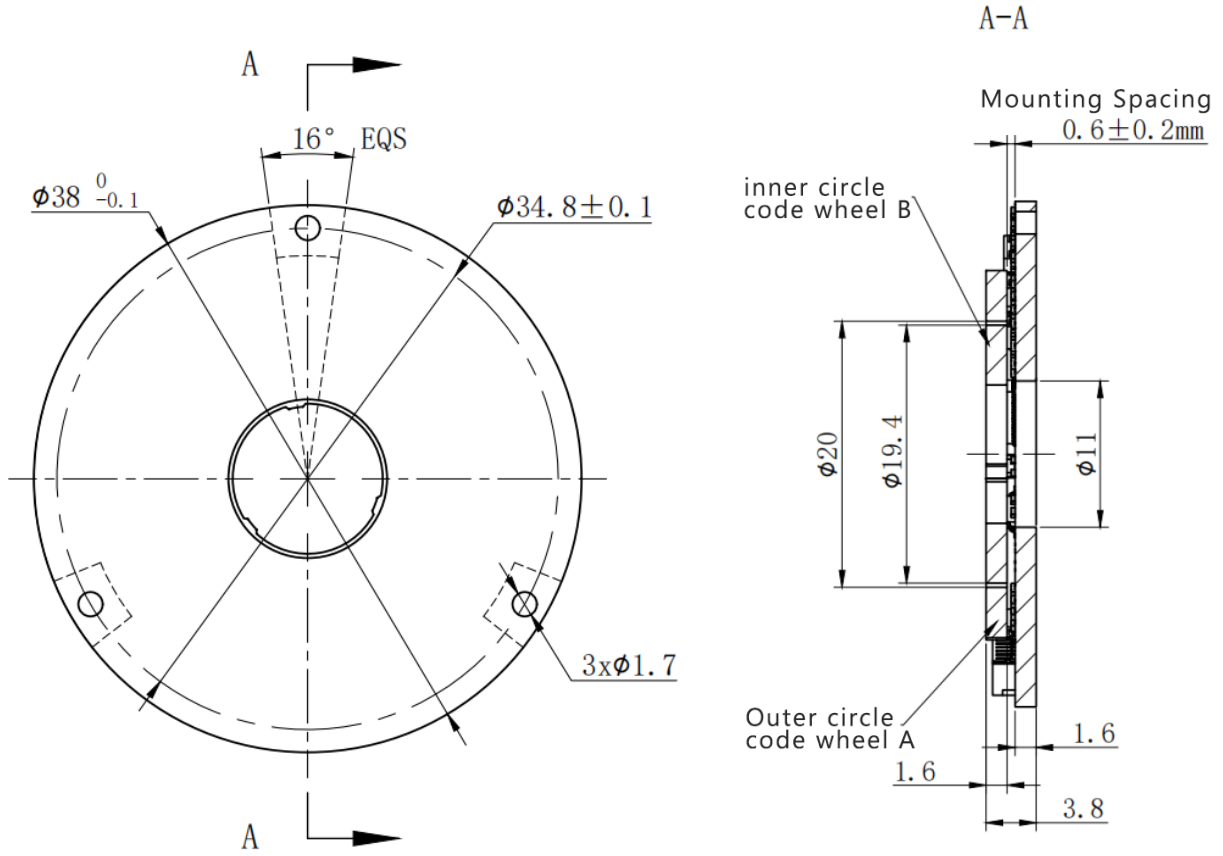

4.2 Installation Diagram

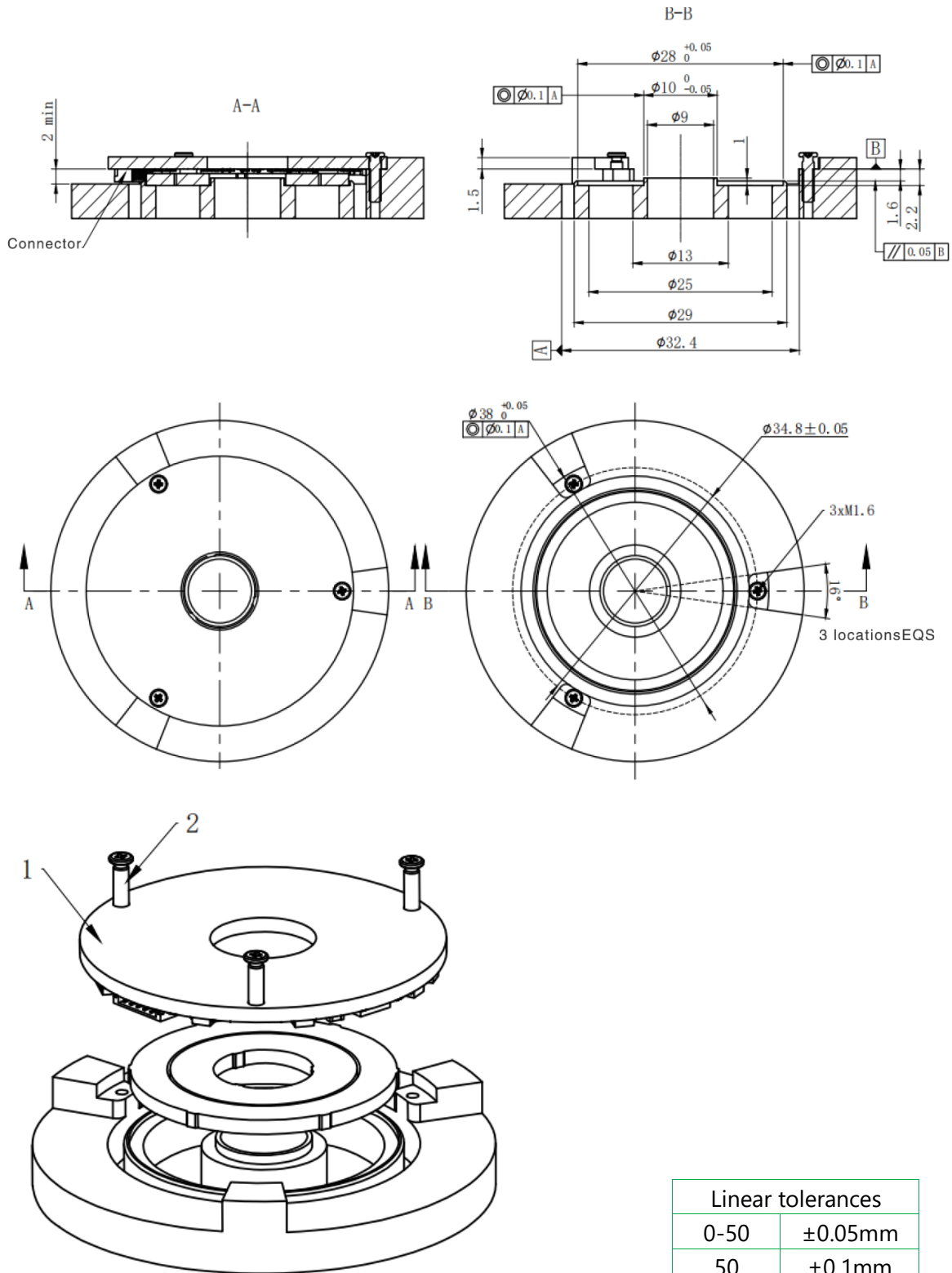

NO.	QTY	Description
1	1	DP1038 Product
2	3	M1.6x6 round head cross screw Install accessories

5、Software Tool

The encoder of the SSi/BiSS-C/RS-422 interface can use the Encoder Test Calibration software for position data readout and installation calibration. The Encoder Test Calibration software owns functions such as position data readout, installation verification, calibration, and user zero position setting.





Domestic website



International website



ShenZhen Mosrac Motor Co., Ltd

E-mail: sales12@mosrac.com

Tel: +8618100274370

Fax: 0755-23091465

Company address: Building 1, COFCO (Fu'an) Robot Technology Park, No. 90 Dayang Road, Bao'an District, Shenzhen, 518103, China

Factory Address: No. 36, Xingda Road, Yanluo Street, Bao'an District, Shenzhen

Website: <http://www.mosrac.com>