

Military industry Medical Industrial Science Micro electronics

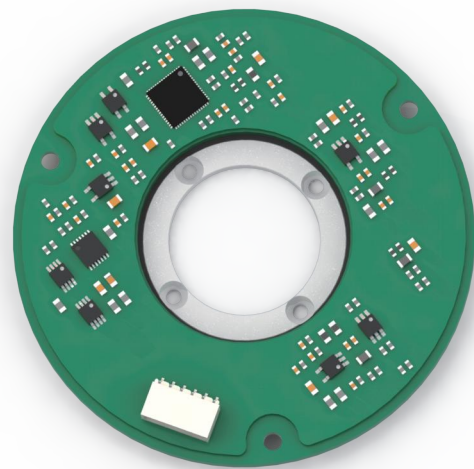

THIN INDUCTIVE ENCODER C1752 PRODUCT MANUAL

I. overview

The C1752 Thin-Profile Inductive Encoder is an inductive angle encoder designed based on non-contact electromagnetic induction principles utilizing wireless power transfer technology.

The product consists of three components: a stator and two rotors. When energized, the stator wirelessly transmits power to the rotors while sensing their electromagnetic fields. The rotors require no power supply, receiving stator energy in real-time to generate a regular electromagnetic field through their coils.

The dual-track design enables absolute angle output. The non-contact, frictionless interface between rotor and stator integrates angle calculation circuitry on the stator. Proprietary technology achieves low power consumption while integrating multiple high-speed digital interfaces.

Both the rotor and stator feature hollow ring-shaped thin-film structures. The large hollow design facilitates easy passage through shafts, cables, and other components. During installation, the stator and rotor must be mounted coaxially and parallel to each other to ensure efficient energy transfer and electromagnetic field induction between them.

The product does not include bearings and requires no coupling during installation, eliminating the need for precision mounting. The absence of components such as ball bearings, glass encoder discs, or light sources enables the inductive encoder to deliver highly reliable angle measurement in harsh environments.

MOSRAC thin-profile inductive encoders find extensive applications in medical, defense, aerospace, industrial automation, and robotics sectors.

- ✓ **Non-contact**
- ✓ **Hollow shaft**
- ✓ **Compact Design**
- ✓ **High Precision**
- ✓ **Absolute Value**
- ✓ **Low Power Consumption**
- ✓ **Maintenance-free**
- ✓ **Coupling-free**
- ✓ **Easy Installation**
- ✓ **Anti-magnetic Interference**
- ✓ **Vibration and Shock Resistant**
- ✓ **Customizable**

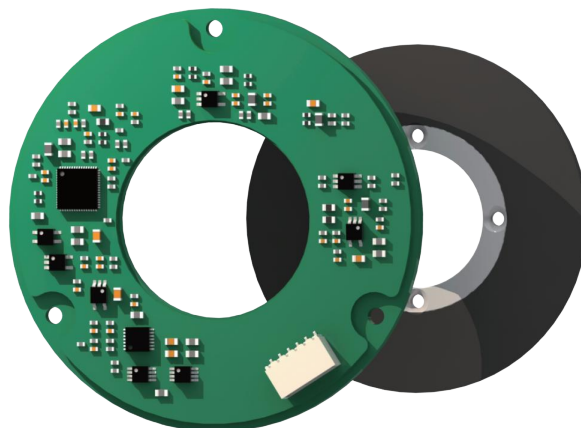

2、 Technical Specifications

Table 1 Encoder Basic Performance Parameters

Angular Resolution	18~20 bit
Maximum static error	±0.01°
Repetitive error	±2 LSB
Maximum operational speed	8000 rpm
Measurement range	Single turn
Rotation direction	Default: Clockwise Increment (Adjustable)

Table 2 Mechanical Dimensions and Installation

Outer Diameter\Inner Diameter\Thickness	52\17\7.6mm
Permissible Installation Eccentricity	±0.1 mm
Stator and rotor installation gap	0.6±0.1 mm
Rotor Inertia	1.18kg·mm ²
Weight (Approx.)	13g
Flame Resistance Rating of Rotor and Stator Materials	FR-4

Table 3 Electrical and Interface Specifications

Power Supply Voltage	5~24V
Current	120~130 mA
Electrical Interface	Six-core connector, six-core shielded cable, eight-core connector (for ABZ protocol use)
Output Protocol	SSi, BiSS-C, RS-422, RS-485, Differential ABZ

Table 4 Environmental Adaptability

EMC	IEC 61000-6-2、 IEC 61000-6-4
Operating temperature	-40°C ~ 125°C
Storage temperature	-50°C ~ +100°C
Relative humidity	0 - 99%
Shock	100 g / 11 ms
Vibration	20 g (10 ~2000 Hz)
Highest Protection Level	IP 40

II. Electrical Interface

3.1 Hardware Interface

The C1752 thin-profile inductive encoder consists of a stator and a rotor. The stator integrates angle calculation circuitry and encoding output circuitry. The encoder employs connector output (as shown below), with angle output utilizing SSI, BiSS-C, RS-422, and RS-485 serial protocols.

Table 5 Communication Interface Cable Definitions

Serial Number	RS-422	SSI	BiSS-C	RS-485	ABZ	Color
1	VCC					Red
2	GND					Black
3	RX+	CLK+	MA+	\	A+	Gray
4	RX-	CLK-	MA-	\	A-	Blue
5	TX-	DATA-	SLO-	B-	B-	Yellow
6	TX+	DATA+	SLO+	A+	B+	Green
7	The default 6-pin connector does not include this feature.				Z+	White
8					Z-	Orange

Table 6 SSI/BiSS Signal Output Parameters

Digital Output Parameters	
Signal Delay	<50us
Output Code	Binary
Fastest Data Update Rate	30kHz
Interface Level	Differential RS-422
Power Consumption	<100mA
When using digital signal acquisition, the sampling rate and clock frequency are related to the communication protocol selected by the user.	

The cable interior features three pairs of 30AWG twisted-pair wires. Each individual conductor consists of 25 strands of 0.05mm tinned copper, with ETFE insulation. The cable shielding employs a thin copper braid with over 95% coverage; the outer jacket is made of 0.4-0.5mm silicone rubber.

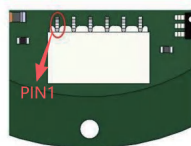

6-pin thin plug: ZX-SH1.0-6PWT
Matching mating plug: ZX-SH1.0-6PJK

8-pin slim plug: HC-1.25-8PWT (Standard version)
HC-0.8-8PWT(Differential ABZ version)

Matching mating plug: HC-1.25-8Y(Standard version)
HC-0.8-8Y (Differential ABZ version)

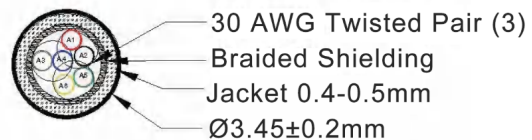

Cable Diameter: $\text{Ø}3.45 \pm 0.2\text{mm}$
Temperature Range: $-50^{\circ} \sim +150^{\circ}\text{C}$

3.2 SSI Interface Protocol

3.2.1 Introduction to Communication Protocol

SSI is an abbreviation for Synchronous Serial Interface, a widely used serial interface between position sensors and a controller. SSI is a unidirectional serial protocol based on RS-422. The unidirectional clock is generated by the master frequency and specified from 0.5MHz to 5.0MHz. Data reception is also unidirectional; SSI does not support propagation delay compensation. The clock is high when inactive. To initiate data transmission, the clock goes low and stores the position. On the first rising edge of the clock signal, the MSB is shifted out at the SSI encoder. On the second rising edge, MSB-1 is shifted out, and so on, until the last bit (LSB) is shifted out. After another clock cycle, the clock remains high until the next data transmission begins. Depending on the timeout, the current latched position or the new position value will be transmitted in the next transmission. The timing diagram is as follows:

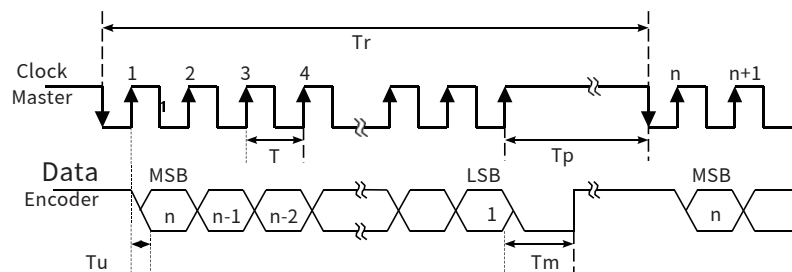

Table 7 Timing Diagram Parameter Description

n	Total Number of Bits in a Frame	12-21
f (T)	Clock Frequency (Clock Cycles)	0.5-5.0MHz
Tu	Update Time for a Single Data Bit	50ns
Tp	Interval Between Data Frames	>25us
Tm	Single Frame Trigger Time	>3us
Tr	Interval Between Two Frames	$Tr > nT + 25us$
$fr = 1/Tr$	Data Frame Frequency	

When selecting a multi-turn product, the multi-turn angle data is placed before the single-turn angle data (MSB), with the higher digit first and the lower digit

3.2.2 Communication Protocol Characteristics

The SSI protocol's core advantage in angle sensors lies in its "synchronous serial + differential transmission" mechanism. By standardizing timing, it lowers the development threshold, making it suitable for scenarios with moderate real-time requirements but demanding high-precision angle calculations. While its unidirectional communication mechanism requires continuous clock driving from the host, it is compatible with traditional industrial controllers (such as PLCs), achieving a balance between cost and performance. This makes it particularly suitable for low-to-medium speed, high-precision industrial automation and medical equipment applications.

3.3 BiSS-C Interface Protocol

3.3.1 Introduction to Communication Protocol

The BiSS-C communication protocol is a full-duplex, bidirectional, high-speed, synchronous serial communication protocol. This interface is also based on the RS-422 hardware standard and is compatible with the SSI interface. It is widely used in absolute encoders for high-precision position control. The product uses a unidirectional BiSS-C interface configured for point-to-point connection, conforming to the requirements of a unidirectional BiSS-C interface. The timing diagram is as follows:

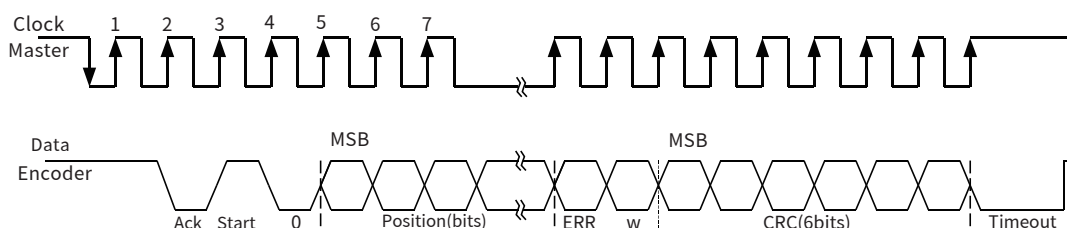

Table 8 Timing Diagram Parameter Description

Bit/n	Code	Meaning	Default Value	Length
28	Ack	Acknowledge Bit	0	1bit
27	Start	Start Bit	1	1bit
26	"0"	Start Bit Follow Bit	0	1bit
8-25	Position	Absolute Position Encoder Data		18bit
7	Error	Error Bit	1	1bit
6	Warn	Warning Bit	1	1bit
0-5	CRC	Checksum		6bit
--	Timeout	Interval Between Data Frames		>30us

The CRC polynomial for position, error, and warning is $x_6 + x_1 + x_0$. The start bit and the "0" bit are not included in the CRC calculation. When a multi-turn product is selected, the absolute position encoder data includes multi-turn angle data and single-turn angle data. The multi-turn angle data precedes the single-turn angle data MSB, following the rule of high-order bits first and low-order bits last.

3.3.2 Timing Characteristics

1. Clock Synchronization: The master device sends CLK, the encoder latches data on the rising edge of the clock, and updates the output on the falling edge (consistent with the "master sends clock, slave responds passively" mechanism of SSI).
2. Multi-Turn Support: Multi-turn angle data is directly embedded in the Position bit field (high bit area), requiring no additional instructions and simplifying angle calculation.

3.4 RS-422 Serial Interface Protocol

3.4.1 Introduction to the Communication Protocol

RS-422 is commonly known as a full-duplex serial interface protocol. It uses four-wire differential transmission (two pairs of twisted pairs), one pair for transmitting data (TX+ and TX-), and the other pair for receiving data (RX+ and RX-). This differential design effectively suppresses common-mode interference and improves the stability of signal transmission. By default, it automatically transmits data to the host without requiring a command from the host.

The data update rate is fixed at 2000Hz, the baud rate is 460800bps, and the data format consists of 1 start bit, 8 data bits, 1 even parity bit, and 1 stop bit. Each data frame contains 10 bytes, as shown in the table below.

Table 9 Frame Data Format

	Sequence Number	Data Type	Remarks
Frame Header	1	5E	Fixed frame header
	2	AD	
Status Bits	3	01	Status Bits
Angle Data	4	Angle Data High Eight Bits	Low bits valid, high bits padded with zeros
	5	Angle Data Middle Eight Bits	
	6	Angle Data Low Eight Bits	
Frame Count	7	Frame Count High Eight Bits	Accumulated value from 0 to 65535
	8	Frame Count Low Eight Bits	
Checksum	9	Checksum High Eight Bits	Accumulated value of 34, 56, and 78 bytes, taking the lower 16 bits
	10	Checksum Low Eight Bits	

3.4.2 Core Advantages

1. **Strong Anti-interference Capability:** Differential transmission effectively resists electromagnetic interference and common-mode interference, ensuring the accuracy of angle data during transmission. It is particularly suitable for environments with strong electromagnetic interference, such as industrial automation and robotics.
2. **Long Transmission Distance:** At a certain baud rate, the transmission distance can reach hundreds of meters, ensuring flexibility in the installation location of the angle sensor within the equipment.
3. **High Real-Time Performance and Reliability:** A fixed data update rate and a robust verification mechanism enable real-time and reliable transmission of angle data, allowing the system to acquire accurate angle information promptly for control and adjustment.

3.4.3 Communication Protocol Characteristics

The RS-422 protocol, in angle sensors, boasts the core advantages of "high-speed full-duplex transmission + strong interference design." Through a fixed frame structure and automatic data transmission mechanism, it balances real-time performance with ease of development, making it particularly suitable for industrial control scenarios with stringent requirements for angle accuracy, response speed, and environmental adaptability.

3.5 RS-485 Serial Interface Protocol

3.5.1 Introduction to Communication Protocol

The RS-485 serial interface protocol is a half-duplex communication protocol that requires the host to send commands to read angle information. The data update rate is related to the host's request rate. The baud rate is 2.5 Mbps, and the data format consists of 1 start bit, 8 data bits, 0 even parity bits, and 1 stop bit. The encoder commands are as follows:

① Encoder Single-Turn Data Request Command:

1. Master Control Terminal Sends Command Frame: Send Data (HEX): 0x02

2. Master Control Terminal Receives Data Frame from Encoder:

Receive Data (HEX): 0x02 0x20 0x03 0x02 0x01 0x16

Where: 0x02: Returns the same command CF;

0x20: Status byte SF is defined as follows (lowest bit first);

Bit0	Bit1	Bit2	Bit3	Bit4	Bit5	Bit6	Bit6
0	0	0	0	EA0	EA1	CA0	CA1

EA0=1 Single-cycle count error;

EA1=1 One of the following: over-temperature, cycle count error, battery alarm, or battery error;

CA0=Communication parity error;

CA1=1 Communication stop bit error;

0x03 0x02 0x01:Single-cycle data value DF (lowest bit first);

0x16:CRC check (XOR operation on all preceding bytes);

② Encoder ID Data Request Command:

1. Master Control Terminal Sends Command Frame: Send Data (HEX): 0x92

2. Master Control Terminal Receives Data Frame from Encoder:

Receive Data (HEX): 0x92 0x20 0x11 0xA3

Where: 0x92: Returns the same command

CF; 0x20: Status byte SF;

0x11: Encoder ID, fixed value = 0x11;

0xA3: CRC checksum (XOR operation performed on all preceding bytes)

③ Encoder Data Request Commands:

1. Master Control Terminal Sends Command Frame: Send Data (HEX): 0x1A

2. Master Control Terminal Receives Data Frame from Encoder:

Receive Data (HEX): 0x1A 0x20 0x03 0x02 0x01 0x11 0x05

0x04 0x00 0x22 0x08

Where: 0x1A: Returns the same command CF; 0x20: Status byte SF;
 0x03 0x02 0x01: Single-turn data value DF (lowest bit first);
 0x11: Encoder ID, fixed value = 0x11;

0x05 0x04 0x00: Cycle count data value DF
 (lowest bit first)
 (0x0405=1029, max.65535);

0x22: Fault content byte ALMC is defined as follows (lowest bit first);

Bit0	Bit1	Bit2	Bit3	Bit4	Bit5	Bit6	Bit7
Overspeed	Low resolution	Single lap count error	Multiple lap count overflow	Over temperature	Multiple lap count error	Battery error	Battery alarm

0x08: CRC check (XOR operation on all preceding bytes);

④ Encoder Single-Turn Reset Request Command

1. Master Control Terminal Sends Command Frame: Send Data (HEX): 0xC2
 The reset command is repeated 10 times at least 40μs intervals to reset the single-turn angle value;

2. Master Control Terminal Receives Data Frame from Encoder:
 Receive Data (HEX): 0xC2 0x20 0x00 0x00 0x00 0xE2

Where: 0xC2: Returns the same command CF; 0x20: Status byte SF;
 0x00 0x00 0x00: Single-turn data value DF (lowest bit first);
 0xE2: CRC check (XOR operation on all preceding bytes);

3.6 ABZ Interface Protocol

3.6.1 Introduction to Communication Protocol

The ABZ interface is a commonly used interface for angle encoders. In the encoder's A-phase, B-phase, and Z-phase signals, the signals of channels A and B are generally orthogonal (i.e., 90° out of phase) pulse signals; while the Z-phase is a zero-pulse signal. When the spindle rotates clockwise, the output pulse signal of channel A precedes that of channel B; when the spindle rotates counterclockwise, the signal of channel A follows that of channel B.

In addition to the A and B phases (the signal sequences of channels A and B have a 90-degree phase difference), the encoder output signal typically also outputs a zero-position pulse or marker pulse (i.e., the Z-phase signal) per revolution to determine the zero position or marker position.

3.6.1 Introduction to Communication Protocol

1. Strong Anti-Environmental Interference: Non-optical design, unaffected by dust, oil, or vibration, suitable for harsh industrial environments.
2. Precise Direction Identification via Quadrature Pulses: Real-time 90° phase difference between AB phases determines rotation direction, combined with pulse counting for angle increment measurement.
3. Zero-Point Calibration Mechanism: Z-phase outputs a single pulse per revolution for mechanical zero-point calibration, eliminating accumulated errors.
4. High-Speed Response and High Cost-Effectiveness: High pulse output frequency supports high-speed rotation detection; simple hardware decoding; lower cost than absolute encoders.
5. Compact Structure and Low Power Consumption: No photoelectric components; small size and low power consumption, suitable for integration into small devices or multi-axis systems.

3.7.2 Communication Protocol Characteristics

The ABZ protocol, based on "orthogonal pulses + zero-point calibration," achieves incremental angle measurement through extremely simple pulse signals. Its advantages include simple hardware decoding, strong real-time performance, and resistance to environmental interference (magnetic encoder, non-optical design). However, it requires an external mechanism to handle power-off reset issues. This protocol is widely used in cost-sensitive motion control scenarios with medium-precision requirements and is one of the mainstream communication solutions for industrial angle sensors.

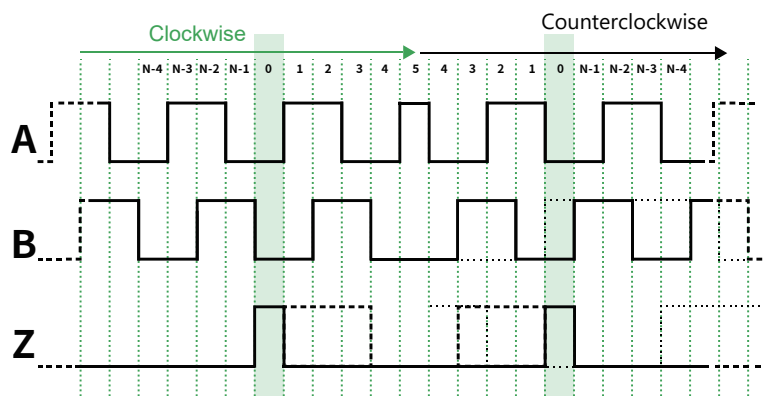

IV. Mechanical Interface

4.1 Product Dimensions

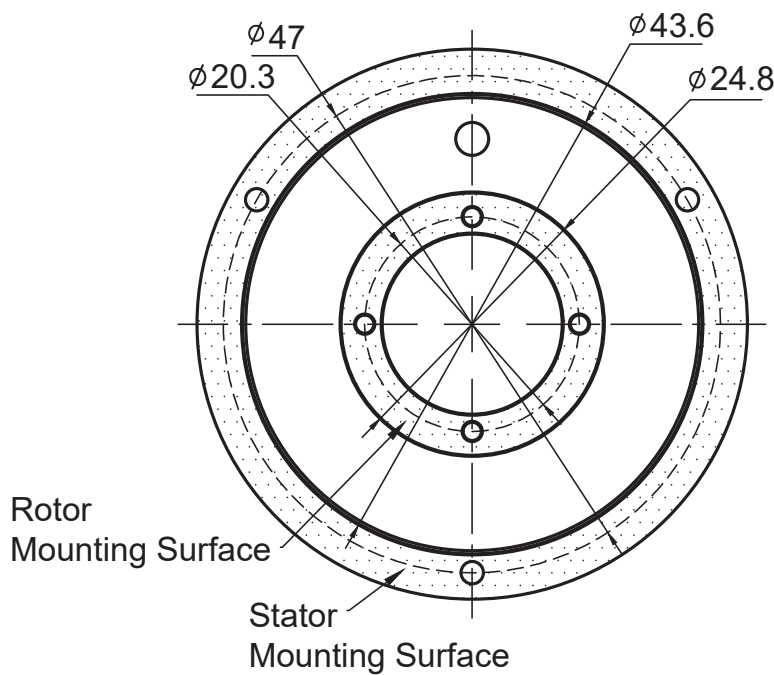
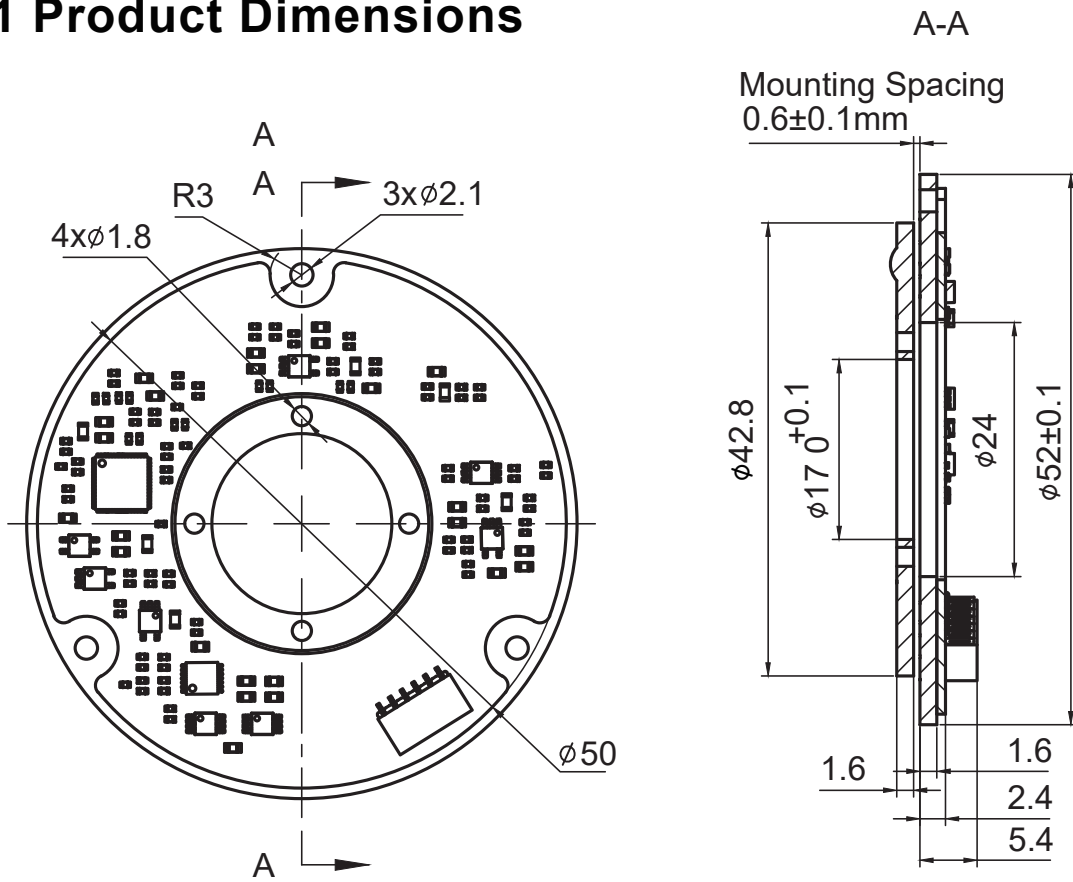

4.2 Product Installation Recommendations

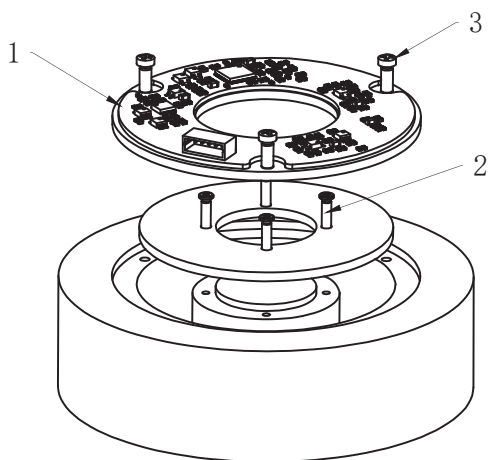
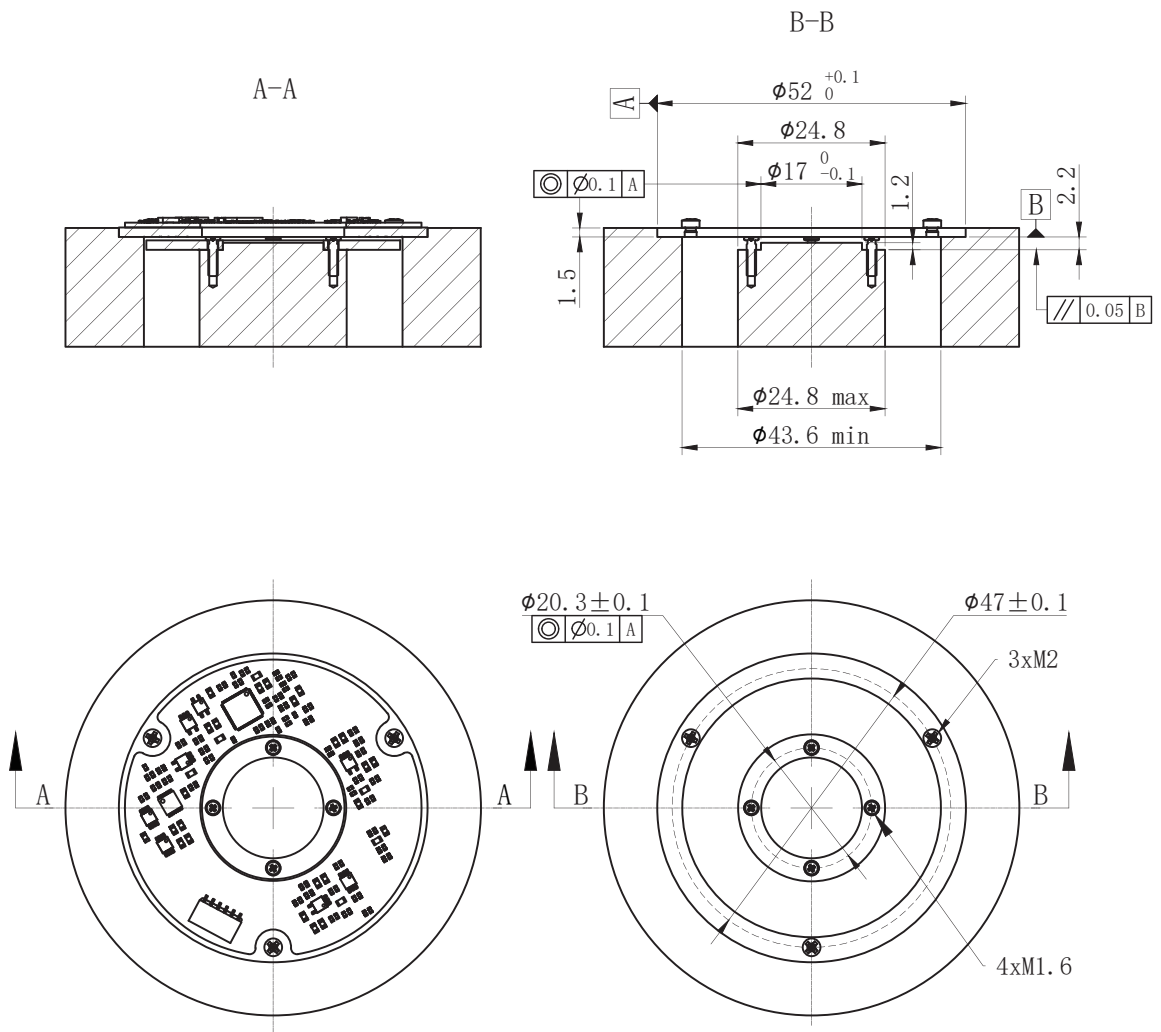

In-diagram tolerances	
0~50	±0.05mm
50~	±0.1mm

Serial Number	Name	Quantity	Remarks
1	C1752	1	Product
2	M1.6X5 small head bolt	2	Product Installation Accessories
3	M2X5 small head bolt	1	

V. Software Tools

Encoder data monitoring and installation calibration can be performed using the encoder calibration and testing software provided by the manufacturer.

The encoder calibration and testing software can perform functions such as data monitoring, installation testing, parameter calibration, and zero-point setting.

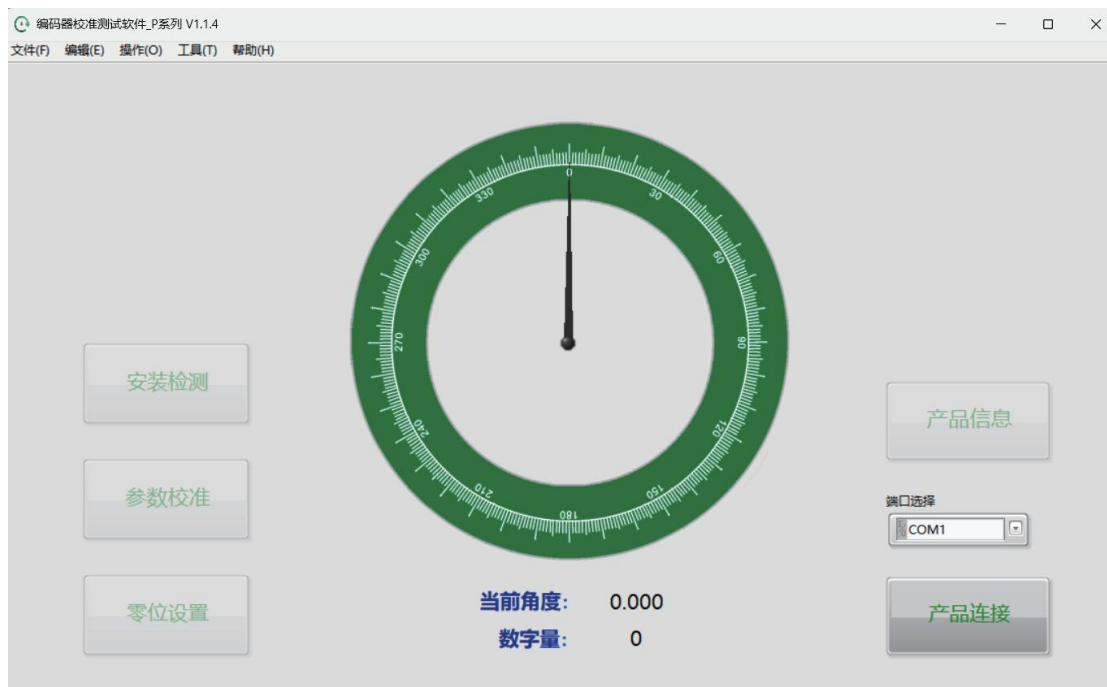



Domestic website



International website



ShenZhen Mosrac Motor Co., Ltd

E-mail: sales12@mosrac.com

Tel: +8618100274370

Fax: 0755-23091465

Company address: Building 1, COFCO (Fu'an) Robot Technology Park, No. 90 Dayang Road, Bao'an District, Shenzhen, 518103, China

Factory Address: No. 36, Xingda Road, Yanluo Street, Bao'an District, Shenzhen

Website: <http://www.mosrac.com>